

iTAC™ M06 with QUAD™ Amplifier

The M06 sensor with QUAD Amplifier is part of the iTac Series of Quality Assurance products.

The M06 Microwave Sensor is used for detecting glue applied by the lower glue wheel (side seam). It works in conjunction with the Array™ and MAQ™ Series Controllers to provide accurate readings of glue placement, including skips and glue volume.

The M06 glue sensor is immune to print and color variation in the board and requires no UV additives to the glue. It works with all normal solid board types except metalized (foil) board or fluted (corrugated) board. An optional built-in shuttle feature is used to set up the station and test the performance by offsetting the sensor from the glue line for zero adjustments and online validation.

- Machine speed 200,000 cartons/hr at 650 m/min (2,150 ft/min)
- Optional integrated shuttle for setup and system validation
- Various mounting options available
- Detects skips as short as 2 mm (.08 in)
- Detects lines as narrow as 2 mm (.08 in)
- Immune to color variation
- Remote teach capability
- Optional built in trigger mounting available

www.whleary.com

QUALITY ASSURANCE

M06 with QUAD Amplifier

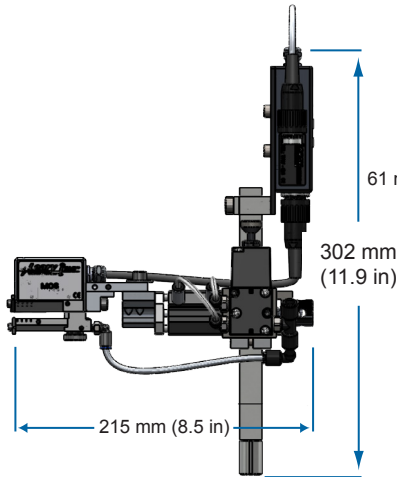

M06 Shuttle Design

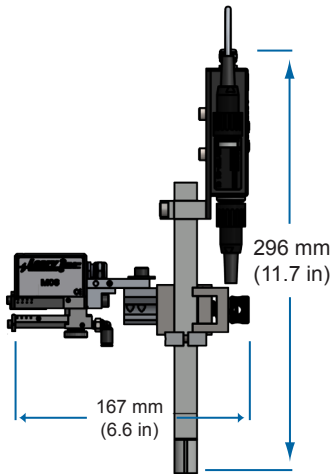
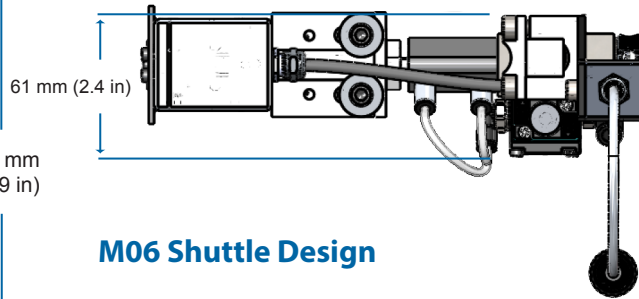

M06 without Shuttle Design

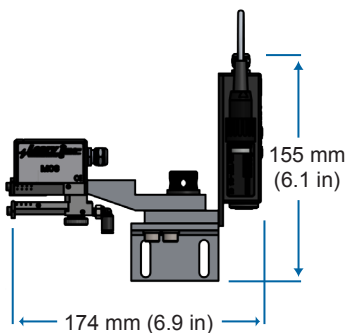
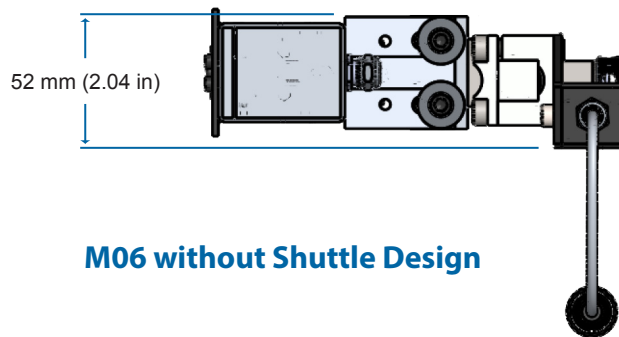

M06 Compact Design

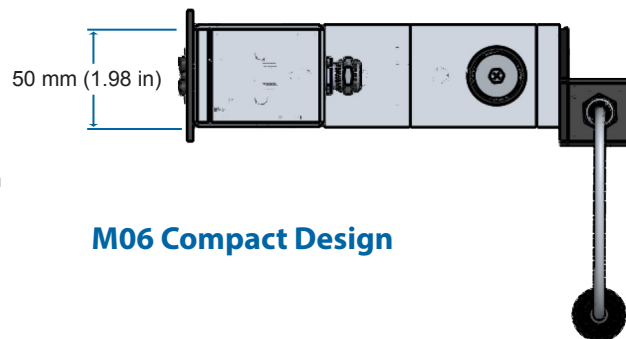

POWER REQUIREMENTS

- 24 VDC for sensor
- 24 VDC for shuttle
- 6 bar (80 psi) required

AMPLIFIER FEATURES

- LED Displays: status, output and light meter indicators
- Learn carton background button
- Learn glue button

SENSOR HEAD FEATURES

- Microwave sensor sensitive to moisture
- Scanning width of 6 mm (.24 in)
- Detects glue lines up to 25 mm (1 in) from the outside edge of the carton
- Detects skips as short as 2 mm (.08 in)
- Detects lines as narrow as 2 mm (.08 in)
- Immune to color variation

MOUNTING OPTIONS AVAILABLE

- Shuttle Design
- Without Shuttle Design
- Compact Design

Corporate Office
8440 B West 183 Place
Tinley Park, IL 60487
USA
PH: +1(708) 444-4900
sales.us@whleary.com
www.whleary.com

European Office
2 Seax Way, Basildon
Essex SS15 6SW
United Kingdom
tel: +44 (0) 1268 490035
info@whleary.co.uk
www.whleary.co.uk

