



LearyVIEW Flex Complete Vision Inspection

The LearyVIEW Flex multi-camera inspection system monitors for glue inside and outside of a specified region, missing flaps, handles, folds and skewed product. Ideally suited for all carton or box applications from eliminating inside stickers on high-speed straight-line machines to complete QA inspection on 6-pack beverage carriers, all using the new LearyVIEW Flex intuitive and simple operating software.

With the ability to set different tolerances for the front and the back of the glue patterns, this camera solution reduces waste by allowing minor preset variation of less critical elements while keeping tight tolerances on those areas that need it. Once a "Golden Image" is created, this can be stored in job memory and provides the reference for all future runs ensuring that quality remains forever consistent from first carton to last. All defects, as a product travels through the machine is monitored.

- Inspect glue in desired target area up to 685 mpm (2,250 fpm)
- Inspect specks of glue outside of target area as small as 2 mm wide
- Monitor for flaps and folds visible in the camera's field of view
- Simple camera FOV setup on Monet operating screen
- Remote diagnostic capability for post-installation support
- Ideal Use:
 - Beverage carriers
 - High speed straight line
 - Confectionery and stencil glue pattern cartons

www.whleary.com

QUALITY ASSURANCE

LearyVIEW Flex

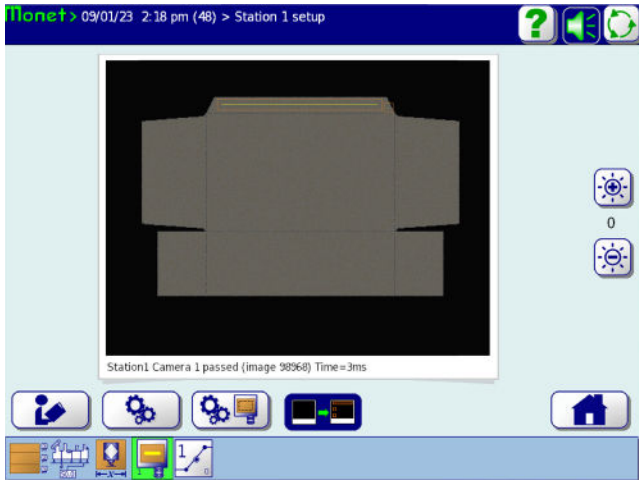

Camera integration into existing Monet interface

ADDITIONAL INSPECTION OPTION



Present flap



Absent flap

CAMERA DIMENSIONS

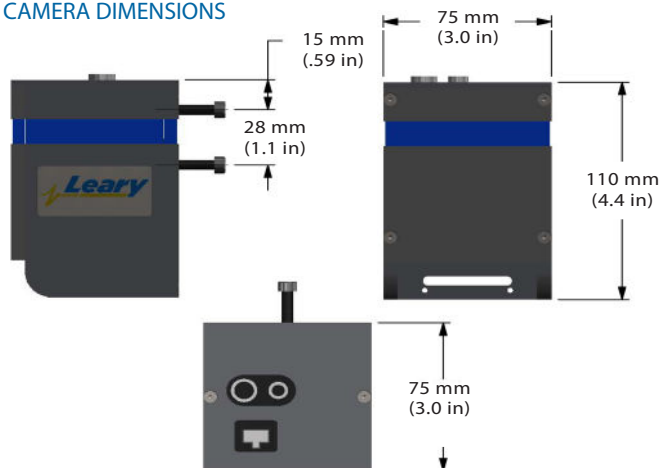

POWER REQUIREMENTS

- Voltage: 85-264 VAC
- Frequency: 47-63 Hz

SYSTEM REQUIREMENTS

- Leary Array controller (MaQ+, LS-904, LS-916, LS-924)
- Available pattern station with valve output
- Ethernet port on the controller
- Monet version 3.0 or higher
- 3365 controller processor or higher

COMPLETE SYSTEM INCLUDES

- LearyVIEW controller
- Inspection camera
- UV Lamp
- Mounting hardware
- Cables
- Trigger

LEARYVIEW FLEX CONTROLLER

- Dimensions:
 - 44 cm (17.0 in) w
 - 31 cm (12.3 in) h
 - 27 cm (10.8 in) d
- Weight: 12 kg (25.5 lbs)

CONFIGURATION OPTIONS

- Filter color option
 - Blue: Standard
 - Green: Ideal for recycled board
- Field of View (FOV) options
 - 100 mm (3.9 in) - single camera
 - 260 mm (10.2 in) - single camera
 - 520 mm (20.5 in) - single camera
 - 1,000 mm (39.4 in) - dual camera
- Camera speeds up to 685 m/min (2,250 ft/min) for all FOV options with product 127 mm (5 in) from lamp
- Dual camera option for maximum FOV coverage

FIELD OF VIEW CAMERA SETUP

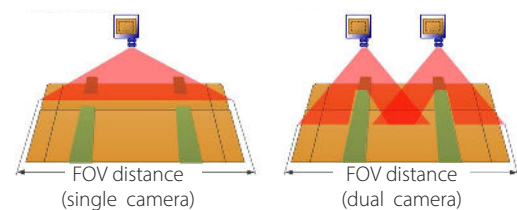

Corporate Office
8440 B West 183 Place
Tinley Park, IL 60487
USA
PH: +1(708) 444-4900
sales.us@whleary.com
www.whleary.com

European Office
2 Seax Way, Basildon
Essex SS15 6SW
United Kingdom
tel: +44 (0) 1268 490035
info@whleary.co.uk
www.whleary.co.uk

