

LearyVIEW™ Braille Complete Braille Inspection

The **LearyVIEW Braille** inspection system combines the most powerful and innovative technologies to achieve in-line Braille detection at full production speeds. With the touch of a button the Braille is learned, decoded and displayed on the screen to be verified as correct by the operator. Once this master is accepted, every subsequent carton is scanned to verify a perfect match.

The LearyVIEW system delivers impeccable quality assurance, checking each and every Braille dot to guarantee all the dots are in exactly the correct position relative to one another and to the carton panel.

Achieve cutting edge quality assurance and performance with the LearyVIEW Braille Inspection System by ensuring Braille remains constant in every way.

- Up to 150,000 cartons/hr
- Available in 5 or 8 line Braille option
- Up to 50 characters per line
- Monitors embossed presence, placement and register
- Simple operator setup
- Flexible mounting for various machine positions
- Integrated with Array™ systems

www.whleary.com

QUALITY ASSURANCE

LearyVIEW Braille

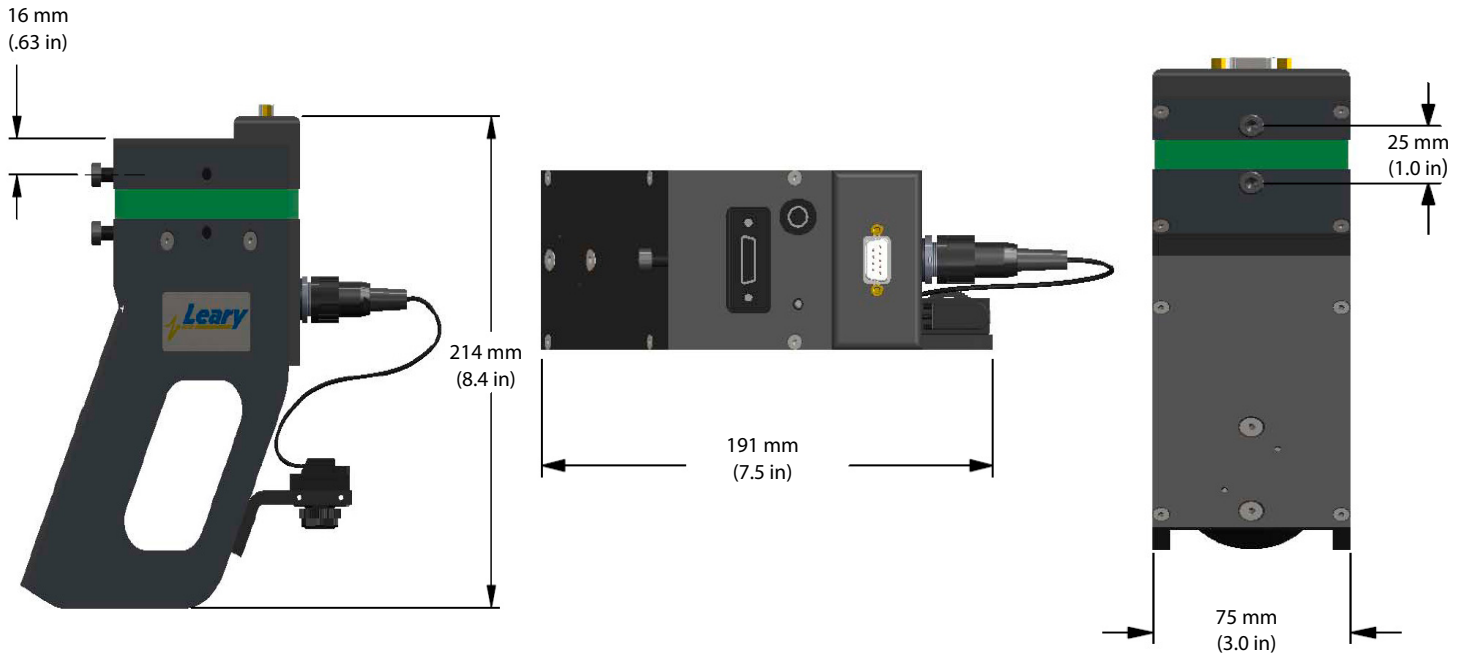

CAMERA

- Dimensions:
 - 191 mm (7.5 in) l
 - 75 mm (3.0 in) w
 - 214 mm (8.4 in) h
- Weight: 1.6 kg (3.5 lbs)

POWER REQUIREMENTS

- Voltage: 85-264 VAC
- Frequency: 47-63 Hz

CONTROLLER

- Dimensions:
 - 44 cm (17.0 in) w
 - 31 cm (12.3 in) h
 - 27 cm (10.8 in) d
- Weight: 12 kg (25 lbs)

COMPLETE SYSTEMS INCLUDES

- LearyVIEW processor
- Braille camera
- Mounting hardware
- Cables
- Trigger

OTHER SPECIFICATIONS

- Available in 5 or 8 line Braille option
- Reads up to 50 characters per line
- Maximum speed: 450 m/min (1,500 ft/min)

SYSTEM REQUIREMENTS

- Leary Array controller (LS-4, LS-916, LS-924)
- Available pattern station with valve output
- Ethernet port on the controller
- Monet™ version 2.39 or higher
- 8120 controller processor

Corporate Office
8440 B West 183 Place
Tinley Park, IL 60487
USA
PH: +1(708) 444-4900
sales.us@whleary.com
www.whleary.com

European Office
2 Seax Way, Basildon
Essex SS15 6SW
United Kingdom
tel: +44 (0) 1268 490035
info@whleary.co.uk
www.whleary.co.uk

