



iTAC™ IR2-L with QUAD™ Amplifier

The iTac IR2-L with QUAD Amplifier is a highly advanced hot melt glue detector using infrared technology. It is capable of detecting for glue absence, presence, placement and volume at line speeds in excess of 650 m/min (2150 ft/min).

Used in conjunction with our Array™ or MAQ™ line of controllers, this sensor takes a comparison reading between the substrate and hot melt adhesive immediately after application.

The iTac IR2-L with QUAD Amplifier works well with the wide range of Robatech hot melt applicator heads, as well as other hot melt applicators.

- High speed detection up to 1 mm (.04 in) at 650 m/min (2150 ft/min)
- Hot melt volume detection
- Light meter indicator for signal strength and sensitivity adjustment
- Remote teach and fine-tune adjustment through Monet interface
- Used with Leary Array and MAQ Controllers
- Available as a stand-alone detection station or as part of hot melt valve gluing station

www.whleary.com

QUALITY ASSURANCE

iTac IR2-L with QUAD™ Amplifier

PHYSICAL CHARACTERISTICS

- Amplifier Dimensions:
 - 25.4 mm (1.00 in) l
 - 25.9 mm (1.02 in) w
 - 88.9 mm (3.50 in) h
- Sensor head Dimensions:
 - 16 mm (0.6 in) l
 - 16 mm (0.6 in) w
 - 18 mm (.7 in) h
- Weight: 810 g (1.8 lbs)

POWER REQUIREMENTS

- 220 mA at 24 VDC

TEMPERATURE RANGE

- 100° - 200° C (212° - 319° F)

AMPLIFIER FEATURES

- LED Displays: status, output and light meter indicators
- Learn carton background button
- Learn glue button
- Remote teach capability

SENSOR HEAD FUNCTIONS

- Focal Distance with Lens: 30 mm (1.18in)

INCLUDED COMPONENTS

- iTac IR-2L sensor head and QUAD Amplifier
- Sensor guard
- Glue sensor cable
- Trigger sensor with cable*
- Bracketry and machine specific mounting

* Trigger is only included with the stand-alone station, when purchased with a valve it uses the valve station trigger.

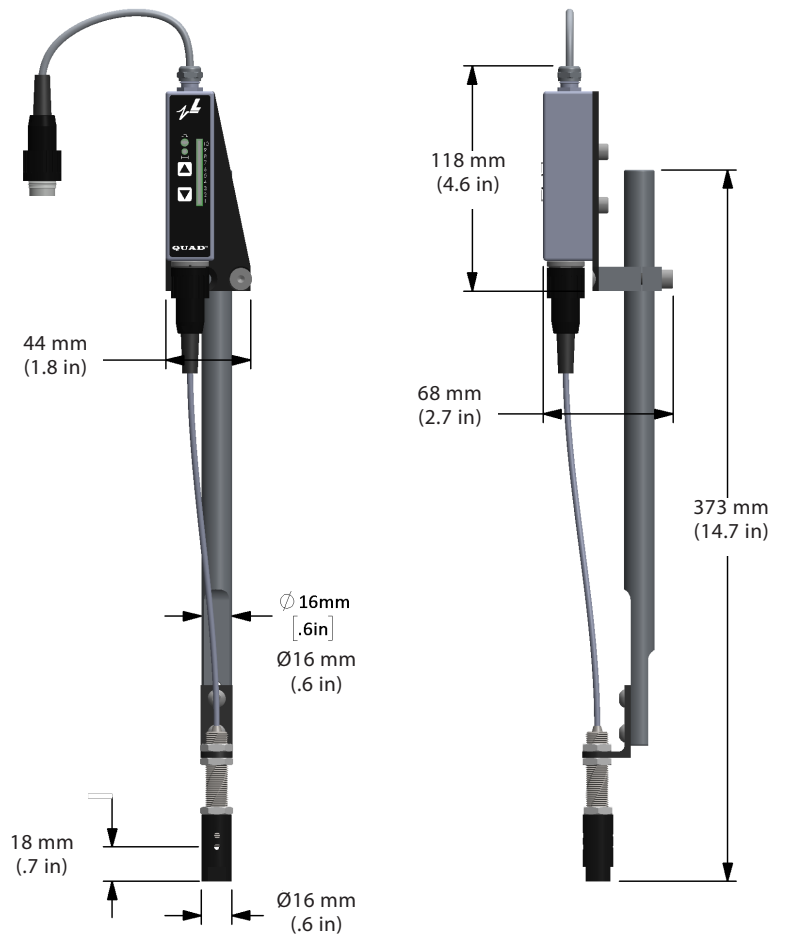

* Dimensional drawing shown as a stand-alone station, also available as part of a hot melt valve kit.

Corporate Office
8440 B West 183 Place
Tinley Park, IL 60487
USA
PH: +1(708) 444-4900
sales.us@whleary.com
www.whleary.com

European Office
2 Seax Way, Basildon
Essex SS15 6SW
United Kingdom
tel: +44 (0) 1268 490035
info@whleary.co.uk
www.whleary.co.uk

