

In-Line Diverter

Leary's automatic product tracking and rejection system accurately identifies and removes non-conforming products from your production line without the need for line stoppages. The In-Line Diverter is able to eject the widest range of solid-board carton styles including 4-corner, 6-corner and crash-lock cartons. It retrofits directly behind the existing trombone section of the folder gluer and requires a gap of 45 cm (18 in) to be created between the trombone and compression section.

After identifying the defect, our patented reject tracking software, along with the encoder and reject trigger, will track the product from the Quality Assurance station to the trombone (transfer) section of the machine where the defective carton will be ejected. The reject fail sensor confirms that the ejection was successful.

- Enhanced with RejectTrak technology
- Eject a single faulty product at speeds of 650 m/min (2,130 ft/min)
- Reject fail sensor ensures that the rejection device fully removes the defective product
- Retrofit to most folder gluers running solid carton board
- Less than 25 ms response time

www.whleary.com

PRODUCT REJECTION

In-Line Diverter

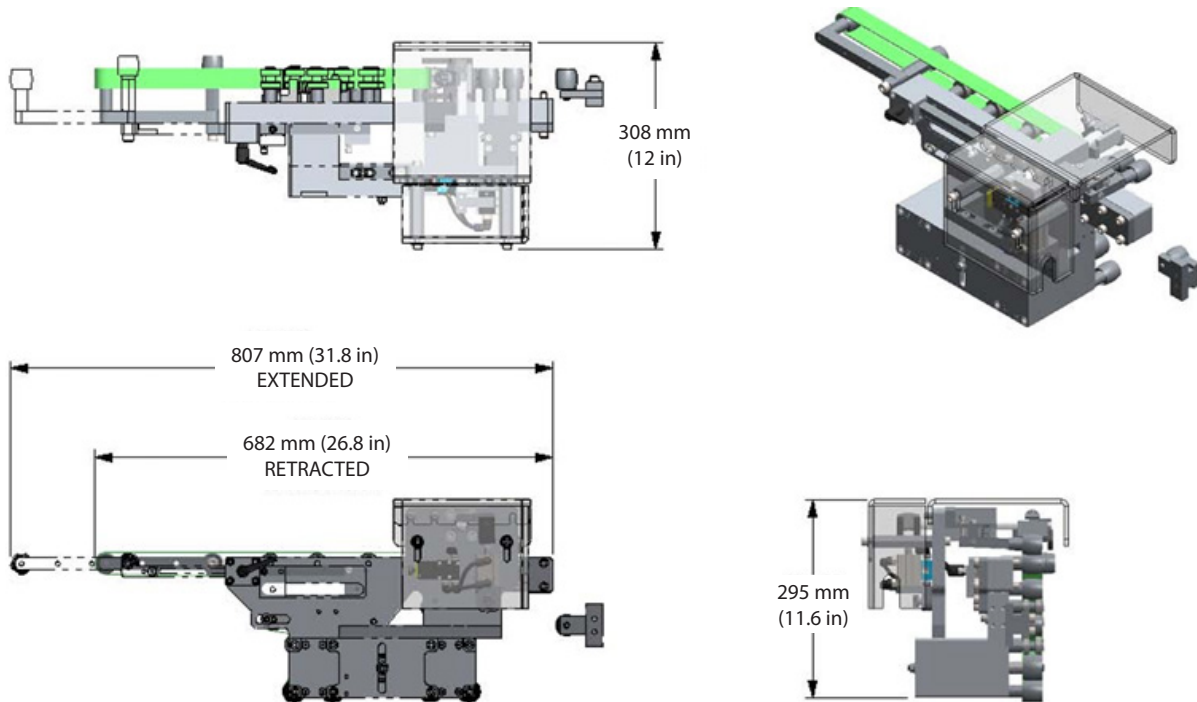

Dimensions may vary based on machine style

PHYSICAL CHARACTERISTICS

- Weight: 34 kg (75 lbs)
- Speed: 550 m/min (1,800 ft/min)

COMPLETE STATION INCLUDES

- In-Line Diverter
- Safety guards for moving pieces
- Reject trigger sensor
- Reject fail sensor
- Encoder
- Cables and Mounting hardware
- Air filter-regulator-lubricator

ADDITIONAL OPTIONS

- Carton adapter for narrow cartons
- Carton adapter for short cartons
- Extended overhang (contact Leary for details)

PRODUCT SELECTIONS

Machine Specific Mounting

- Specific mounting based on the machine make and model are available for machines including Bobst, Brause, Duran, Heidelberg, International, IPBM, Post, Signature, Sun, Taeyong, and Vega.

Carton Adapters

Standard carton size:

- Cartons as small as 88.9 mm (3.5 in) L x 63.5 mm (2.5 in) W

Short carton kit:

- Cartons as small as 44.4 mm (1.8 in) L

Narrow carton kit:

- Cartons as small as 38.1 mm (1.5 in) W

Carton Overhang

- Standard carton overhang: 110 mm (4.25 in)
- Extended overhang:
 - Adds 76.2 mm (3.0 in) of overhang to each side

Encoder

- Specific encoder options based on pulse per revolution, wheel size and wheel finish

Corporate Office
8440 B West 183 Place
Tinley Park, IL 60487
USA
PH: +1(708) 444-4900
sales.us@whleary.com
www.whleary.com

European Office
2 Seax Way, Basildon
Essex SS15 6SW
United Kingdom
tel: +44 (0) 1268 490035
info@whleary.co.uk
www.whleary.co.uk

