



## iCheck Camera

Leary's iCheck smart camera comes with a flexible tool library offering a wide range of inspection options. Simple programming features allow operators to quickly setup inspection of labels, inserts, text, date codes, flaps and more.

iCheck can be integrated with all existing Leary systems to allow for quality inspection and rejection. Multiple interface options are available for setup and display based on Array controller model.

- Inspects labels, inserts, text, date codes, flaps, and more
- Equipped with pattern recognition
- Simple programming features reduce operator setup time
- Integration with most existing Leary Array systems
- Flexible to use for a variety of quality assurance needs

[www.whleary.com](http://www.whleary.com)

QUALITY ASSURANCE

# iCheck Camera

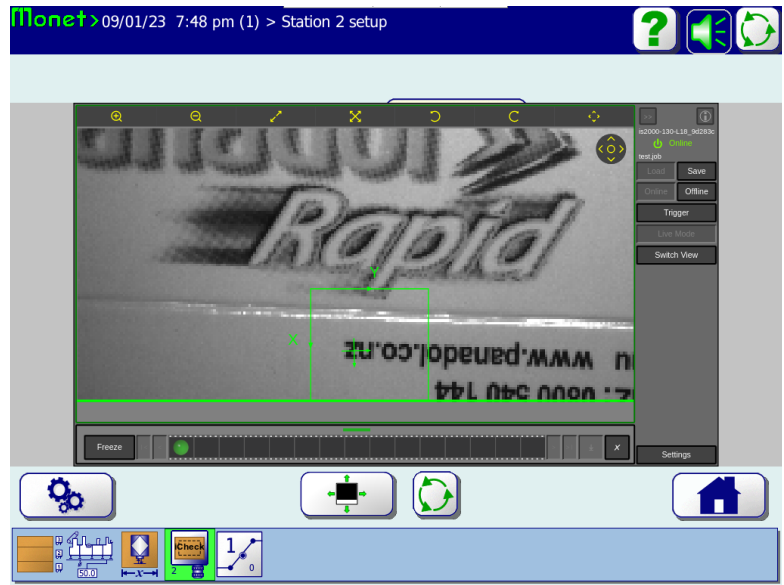

iCheck display integration with Monet 3.0 OS

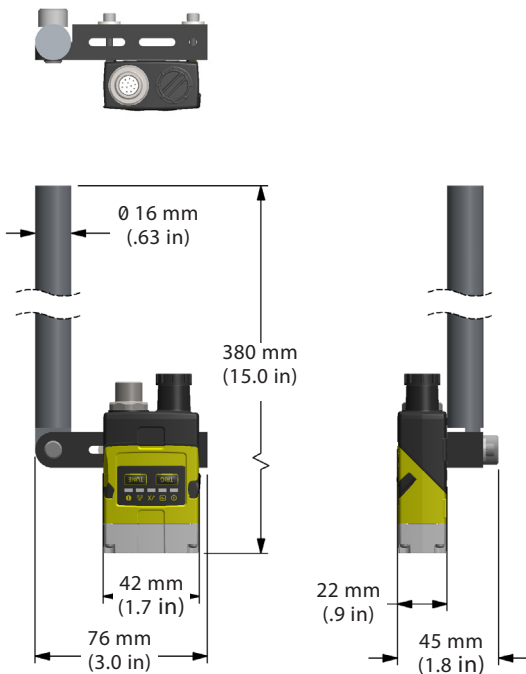

## POWER REQUIREMENTS

- Class 3 PoE 5W

## COMPLETE STATION INCLUDES

- Camera
- Mounting hardware
- Cables
- Trigger
- Camera display option

## SYSTEM REQUIREMENTS

- Leary Array controller
- Ethernet port on the controller
- (1) Available detection pattern input
- (1) Available valve output
- Monet 2.x when used with external display
- Monet 3.0 or higher when display is integrated through Monet

## CAMERA DISPLAY OPTIONS

	Monet 3.X OS	Monet 2.X OS
Image displayed on Array LSI screen after setup	●	
Image displayed on 7-inch touch remote screen after setup	Optional	●
Camera setup and changing inspection parameters for jobs	Windows computer machine-side (OR) via iQ Remote Access	Windows computer machine-side

Corporate Office  
 8440 B West 183 Place  
 Tinley Park, IL 60487  
 USA  
 PH: +1(708) 444-4900  
 sales.us@whleary.com  
 www.whleary.com

European Office  
 2 Seax Way, Basildon  
 Essex SS15 6SW  
 United Kingdom  
 tel: +44 (0) 1268 490035  
 info@whleary.co.uk  
 www.whleary.co.uk

