

## HIGH PRESSURE CXPP 110 PISTON PUMP UPGRADE OFFER

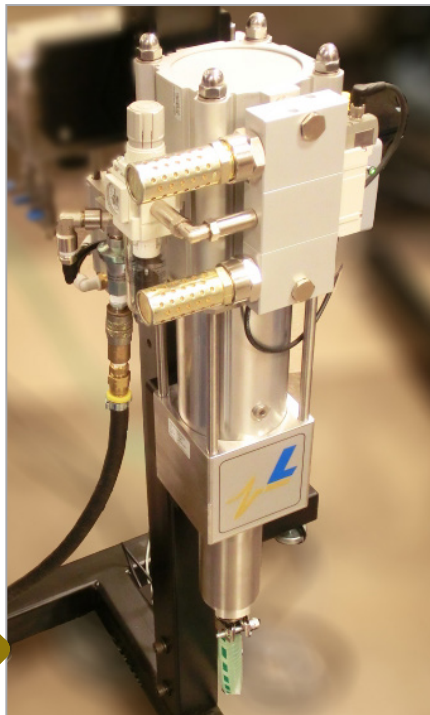

4:1 / 9:1 Pump



CXPP 110 Pump

The **High Pressure CXPP 110 Piston Pump** utilizes advanced glue feed technology for accurate, consistent control of glue pressure. The CXPP 110 pump is ideal for use in high speed applications with multiple valve outputs and allows for a wide glue viscosity range.

Available as an upgrade kit to utilize an existing 2:1 or 5:1 GRU, the CXPP 110 replaces the original 4:1 or 9:1 pump. The new high performance pump shaft seals are designed to be long lasting and can be changed in the field in minutes, eliminating long downtimes and high costs for rebuilds. The CXPP 110 pump is also designed to work with sensitive glues to eliminate glue shearing, which leads to excessive clogging in the filters and reduces system performance.

- Model CXPP 110 high pressure 9:1 pump
- Low maintenance with high performance sealing kits
- Long lasting stainless steel parts throughout
- Reduces glue shearing
- Glue viscosity range: 0.5 - 12.5 Pa·s (500 - 12,500 cps)\*
- [Trade-in credit for upgrading to new pump \(GFU04\)](#)

\*The viscosity range quoted relates to this product only. For viscosity ranges for the complete system, please also check the relevant glue valve data.

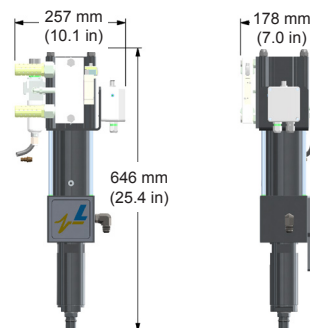

### Dimensions:

257 mm (10.1 in) w  
646 mm (25.4 in) h  
178 mm (7.0 in) d

**Weight:** 20 kg (44.1 lbs)