

COLD GLUE FEED



COLD GLUE FEED

PUMP AND GRU SOLUTIONS

Leary's line of Cold Glue Pumps and Glue Regulation Units (GRU's) have been designed to deliver extremely accurate glue volume control for the widest range of adhesives and applications.

These glue feed solutions utilize advanced technology via closed-loop communication between the GRU, pump and controller to maintain precise application. Pressure requirements are programmed and maintained through the Monet controller operating system. Each glue feed system can be matched to specific controllers and cold glue valves for optimum performance.

- Range of pump and GRU options based on application requirements
- Consistent and accurate glue application
- Closed-loop communication with GRU and controller to maintain constant glue pressure

Adapting to a variety of adhesive types and machine speed ranges, these are designed to eliminate puddling, glue line variation and glue pattern drifting due to pressure inconsistencies. User friendly filter changes, and fast, easy machine-side maintenance keep machines running and reduces downtime to a minimum.

Ensure optimal performance and longevity with Predictive Maintenance Notifications and new 'run-away protection' feature that automatically shuts down the pump if excessively cycling speeds are detected, allowing safe and effective remedy of the issue.

- Long lasting design with high performance pump seals
- Easy to maintain at the machine
- Upgrade and rebuild kits available

PUMP AND GRU OPTIONS					
	Low Pressure Tank 19 liter (5 gal)	Low Pressure Pump	GT51 Pump	CXU 110 Pump	High Pressure Diaphragm Pump
Pump	N/A	1:1	5:1	9:1	4:1
Fluid Regulation	Air / Optional 1:1	2:1	4:1	6:1	6:1
Glue Viscosity Range*	0.2 - 0.6 Pas (200 - 600 cps)	0.2 - 0.6 Pas (200 - 600 cps)	0.3 - 2 Pas (300 - 2,000 cps)	0.5 - 12.5 Pas (500 - 12,500 cps)	0.2 - 15 Pas (200 - 15,000 cps)
Max Fluid Pressure	6 bar (80 psi)	6 bar (80 psi)	22 bar (325 psi)	30 bar (435 psi)	16.5 bar (239 psi)
Min Fluid Pressure	0.3 bar (5 psi)	1.4 bar (20 psi)	3.8 bar (55 psi)	4.8 bar (70 psi)	4.8 bar (70 psi)
Pressure Dumping		Optional	Internal	Internal	Internal
Actual Pressure Reading			Optional Monet 2.9+ required	Optional Monet 2.9+ required	Optional Monet 2.9+ required
All Stainless-steel				Optional	Optional
Standard manifold size	4 valve	4 valve	8 valve	8 valve	8 valve
Max. Valve Outputs	Up to 24	Up to 24	Up to 24	Up to 24	Up to 64
CleanStart air manifold			Optional	Optional	Optional
Predictive Maintenance			Monet 3.3+ required	Monet 3.3+ required	
Run-away Protection			Monet 3.3+ required	Monet 3.3+ required	

PREDICTIVE MAINTENANCE NOTIFICATIONS

Predictive Maintenance notifies the operator of recommended GRU and pump maintenance to continually deliver optimal glue pressure and precise application. Cycle counts and times are tracked to determine when routine maintenance should occur. Monet 3.3 or above is required.

Maintenance Notifications:

- Clean filter
- Check glycerin level
- Replace seals

Service Level Notifications:

- Warning level shown in pump cycles and days
- Critical level shown in pump cycles and days

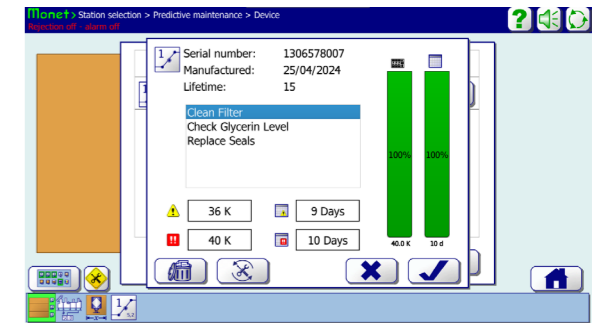

Main Predictive Maintenance Dialogue Box

	36.0 K	40.0 K	9	10	
1	36.0 K	40.0 K	9	10	
2	36.0 K	40.0 K	9	10	

Predictive Maintenance Service Dialogue Box

GLUE FEED OPTIONS



Low Pressure Tank



Low Pressure Pump

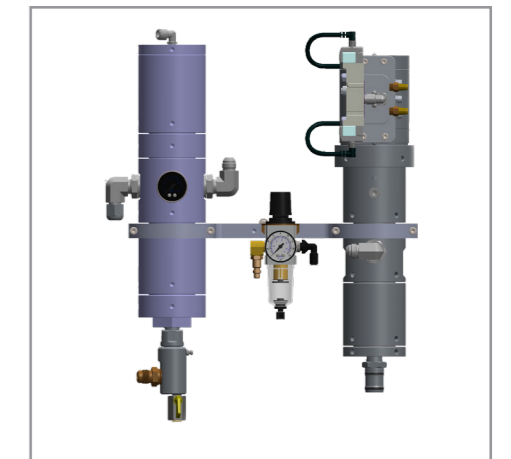

GT51 Pump



CXU 110 Pump

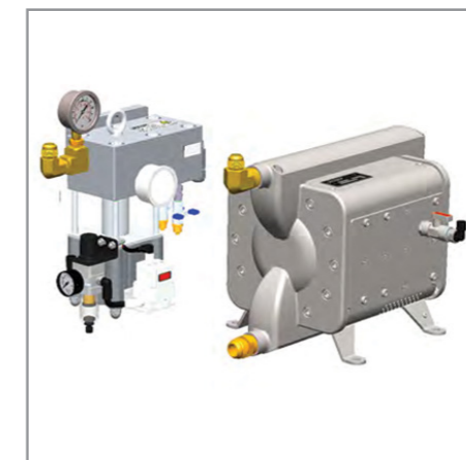

High Pressure Diaphragm Pump

Configuration Options:

- Pump and GRU options
- Mounting configurations
- Manifold type and hose length
- Glue siphon tube and glue supply hose
- Optional low glue level alarm

RECOMMENDED PUMP AND GRU

Use the table to determine the ideal pump and GRU recommendation. This is based on your machine speeds, viscosity of adhesive and pressure requirements.

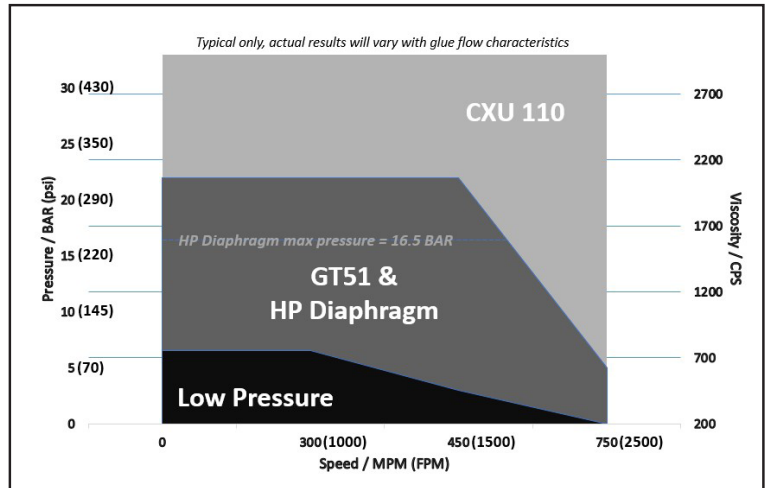

PUMP AND GRU DIMENSIONS

Low Pressure Tank

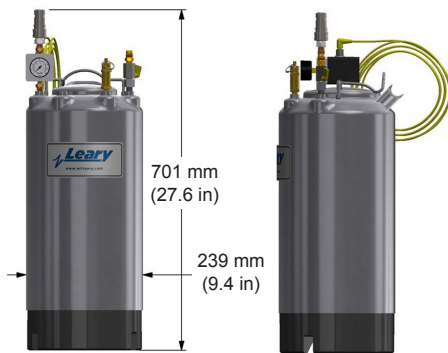

Low Pressure Pump

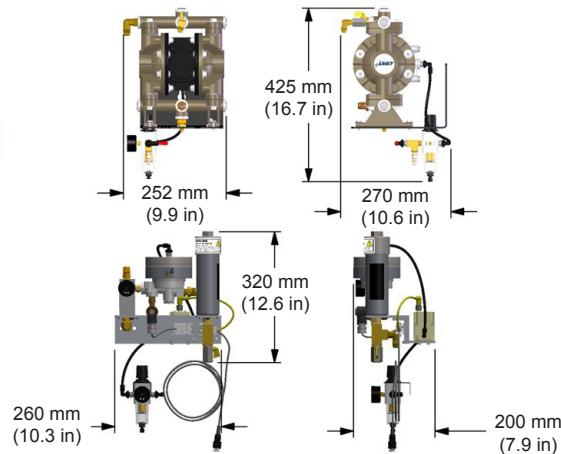

GT51 Pump

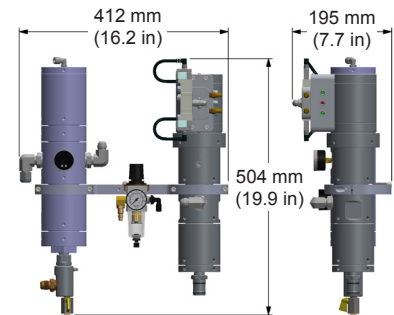

CXU 110 Pump

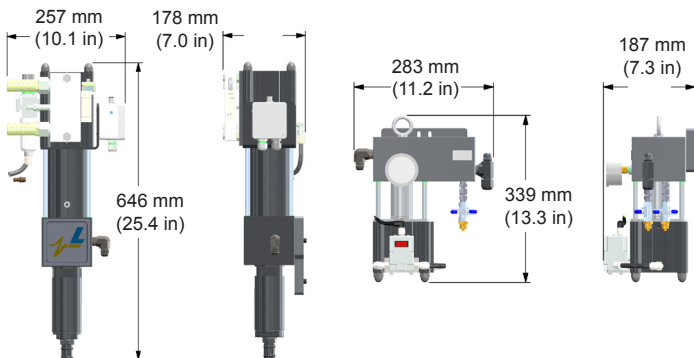

High Pressure Diaphragm Pump

